

FLUSH DIAPHRAGM TRANSDUCER WITH AMPLIFIED VOLTAGE OUTPUT STAINLESS STEEL WETTED PARTS

PX103U Series

0.5 to 5.5 Vdc Output

0-15 to 0-20,000 psi

0-1 to 0-1300 bar

1 bar = 14.5 psi

1 kg/cm² = 14.22 psi

1 atmosphere = 14.7 psi = 29.93

inHg = 760.2 mmHg = 1.014 bar

Starts at
\$495



PX103U0-025G5V, \$495,
shown actual size.

PX103U1-025G5V, \$495,
shown actual size.

MOST POPULAR MODELS HIGHLIGHTED!



- ✓ All Stainless Steel
- ✓ Amplified Voltage Output
- ✓ Flush Diaphragm for Hard-to-Measure Fluids
- ✓ Ideal for Tank and Level Applications

OMEGA's PX103U voltage transmitters feature a rugged all stainless steel case and a high-reliability, low-noise 0.5 to 5.5 Vdc output. They are designed for use in critical applications in wastewater management, chemical manufacturing, water processing, tank and level applications, and other industrial applications where a non-plugging flush diaphragm is needed.

ACCESSORY

MODEL NO.	PRICE	DESCRIPTION
PT06F10-6S	\$26.50	Mating connector for PX103U1 series transducers

To Order (Specify Model Number)

RANGE		MODEL NO.	PRICE	COMPATIBLE METERS**
ABSOLUTE PRESSURE (All Ranges Available in Absolute Pressure)				
0 to 15 psi	0 to 1 bar	PX103U[*]-015A5V	\$565	DP41-E, DP25B-E, DP24-E
0 to 25 psi	0 to 1.7 bar	PX103U[*]-025A5V	565	DP41-E, DP25B-E, DP24-E
0 to 50 psi	0 to 3.4 bar	PX103U[*]-050A5V	565	DP41-E, DP25B-E, DP24-E
GAGE PRESSURE (All Ranges Also Available in Sealed Gage Pressure)				
0 to 15 psi	0 to 1 bar	PX103U[*]-015G5V	\$495	DP41-E, DP25B-E, DP24-E
0 to 25 psi	0 to 1.7 bar	PX103U[*]-025G5V	495	DP41-E, DP25B-E, DP24-E
0 to 50 psi	0 to 3.4 bar	PX103U[*]-050G5V	495	DP41-E, DP25B-E, DP24-E
0 to 100 psi	0 to 6.9 bar	PX103U[*]-100G5V	555	DP41-E, DP25B-E, DP24-E
0 to 200 psi	0 to 13.8 bar	PX103U[*]-200G5V	555	DP41-E, DP25B-E, DP24-E
0 to 500 psi	0 to 34.5 bar	PX103U[*]-500G5V	555	DP41-E, DP25B-E, DP24-E
0 to 1000 psi	0 to 68.9 bar	PX103U[*]-1KG5V	555	DP41-E, DP25B-E, DP24-E
0 to 2000 psi	0 to 138 bar	PX103U[*]-2KG5V	555	DP41-E, DP25B-E, DP24-E
0 to 3000 psi	0 to 207 bar	PX103U[*]-3KG5V	555	DP41-E, DP25B-E, DP24-E
0 to 5000 psi	0 to 345 bar	PX103U[*]-5KG5V	555	DP41-E, DP25B-E, DP24-E
0 to 10,000 psi	0 to 689 bar	PX103U[*]-10KG5V	555	DP41-E, DP25B-E, DP24-E
0 to 15,000 psi	0 to 1034 bar	PX103U[*]-15KG5V	555	DP41-E, DP25B-E*, DP24-E
0 to 20,000 psi	0 to 1379 bar	PX103U[*]-20KG5V	555	DP41-E, DP25B-E*, DP24-E

Comes complete with 5-point NIST traceable calibration.

Metric ranges available – consult Engineering.

* 4-digit meter, counts by 10.

** See section D for compatible meters.

[*] To order cable style insert "0" into model number; to order connector style insert "1".

To order absolute pressure ranges, replace "G" in model number with "A" and add \$70.

To order sealed gage pressure ranges, replace "G" in model number with "S" (no extra charge).

To order extra lead length (10' standard) add suffix "--(Length of cable in feet)" and \$2/ft to the length beyond 10'.

Ordering Examples: PX103U0-050G5V, 50 psi gage pressure cable style transducer with 0.5 to 5.5 Vdc output, \$495. PX103U1-050A5V, 50 psi absolute pressure connector style transducer with 0.5 to 5.5 Vdc output, \$555 + 70 = \$625. PT06F10-6S, mating connector (sold separately), \$26.50. PX103U0-200S5V-25FT, 200 psi sealed gage pressure cable style transducer with 0.5 to 5.5 Vdc output and 7.6 m (25') leads, \$555 + 30 = \$585.

FLUSH DIAPHRAGM TRANSMITTER

VOLTAGE OUTPUT
PRESSURE TRANSDUCERS
B

SPECIFICATIONS

5.5 Vdc OUTPUT

Excitation: 24 to 32 Vdc

Output: 0.5 to 5.5 Vdc
(0.5 to 10.5 Vdc optional)

Zero Balance: 0.5V ±0.1V

Accuracy:

<100 psi: ±1% FSO linearity,
hysteresis and repeatability
combined

≥100 psi: ±0.5% FSO linearity,
hysteresis and repeatability
combined

Operating Temp Range:

<100 psi: -45 to 93°C (-50 to 200°F)

≥100 psi: -45 to 121°C (-50 to 250°F)

Compensated Temp Range:

<100 psi: -1 to 54°C (30 to 130°F)

≥100 psi: -18 to 66°C (0 to 150°F)

THERMAL EFFECTS

<100 psi:

Span: <±2% within
compensated range

Zero: <±1% within
compensated range

≥100 psi:

Span: ±0.003% rdg/°F

Zero: ±0.0045% FSO/°F

Ranges (psi): 5, 15, 25, 50, 100, 200,
500, 1K, 5K, 10K, 20K; gage, sealed
gage or absolute; metric ranges also
available

Proof Pressure:

<100 psi: 200% of rated pressure

≥100 psi: 150% rated pressure

30,000 psi: maximum

Burst Pressure:

<100 psi: 500% of rated pressure

≥100 psi: 300% of rated pressure

50,000 psi: maximum

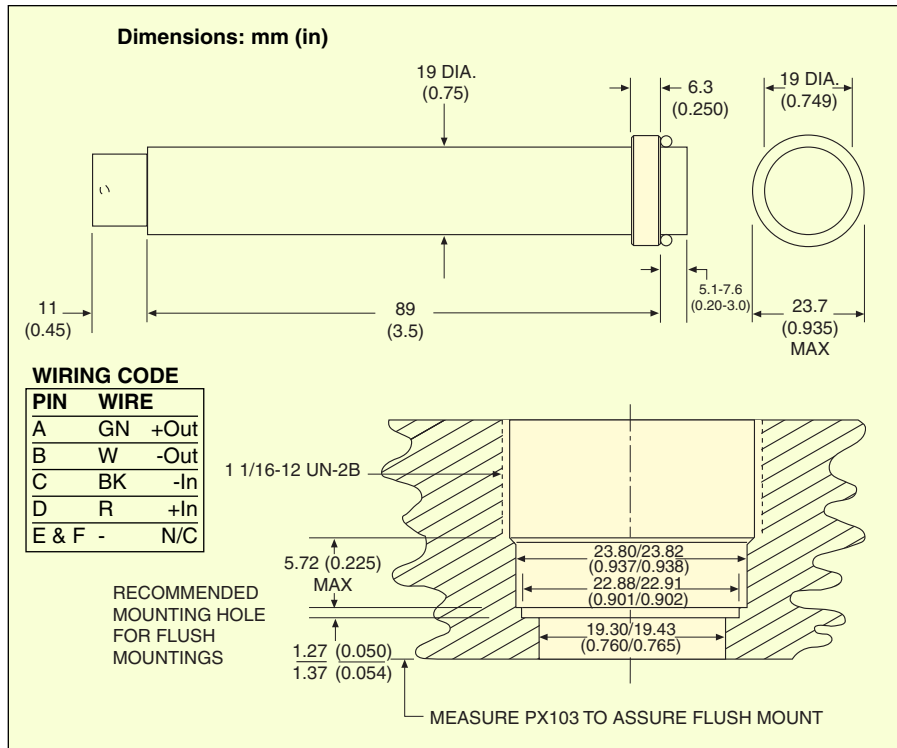

Wetted Parts:

Ranges <100 psi: 316 stainless steel

Ranges ≥100 psi: 17-4 PH stainless steel

Pressure Port:

Flush diaphragm

O-Ring: #2-018, sold separately

Electrical Connection: 3 m (10')
4-conductor shielded PVC cable or
PTIH-10-6P or equal

Mating Connector:

PT06F10-6S (sold separately)

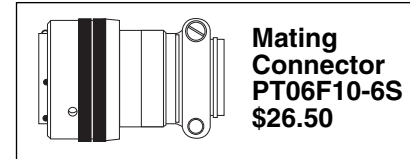

Flush Mount Adaptors for Series PX103 Transducers

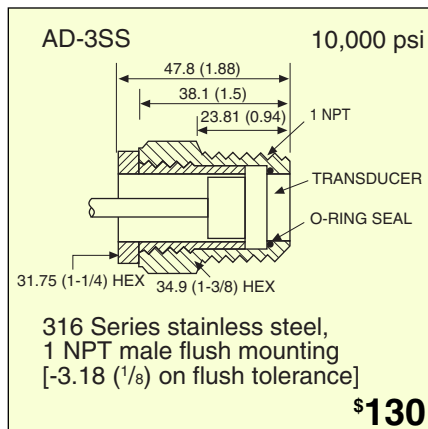
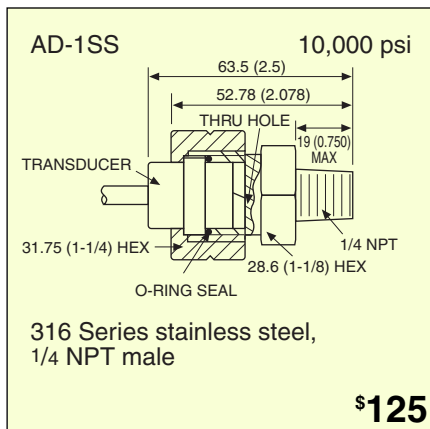

“O” RINGS FKM or Polyurethane

Use for pressures under
10,000 psi:

#2-018-V

FKM\$10/Pk of 10

Use for pressures of
10,000 psi and higher:

#2-018-P

POLYURETHANE .. \$15/Pk of 10

O-Ring Provided with Each Adaptor

Dimensions: mm (in)